

BVM CENTER LATCH ELEVATOR TYPE "TA"

BVM's TA-35; TA-65; TA-100; and TA-150 are high collar type center latch elevators for API drill pipe, casing and tubing. They range in size from 1.050" through 8 5/8". BVM elevators are made from alloy steel, heat treated and magnetic particle inspected. All steel specifications are certified.

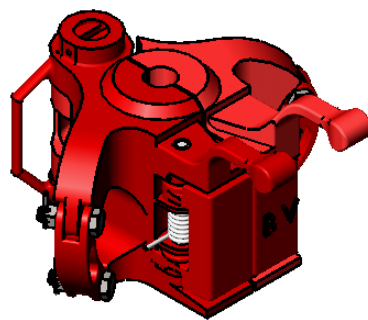
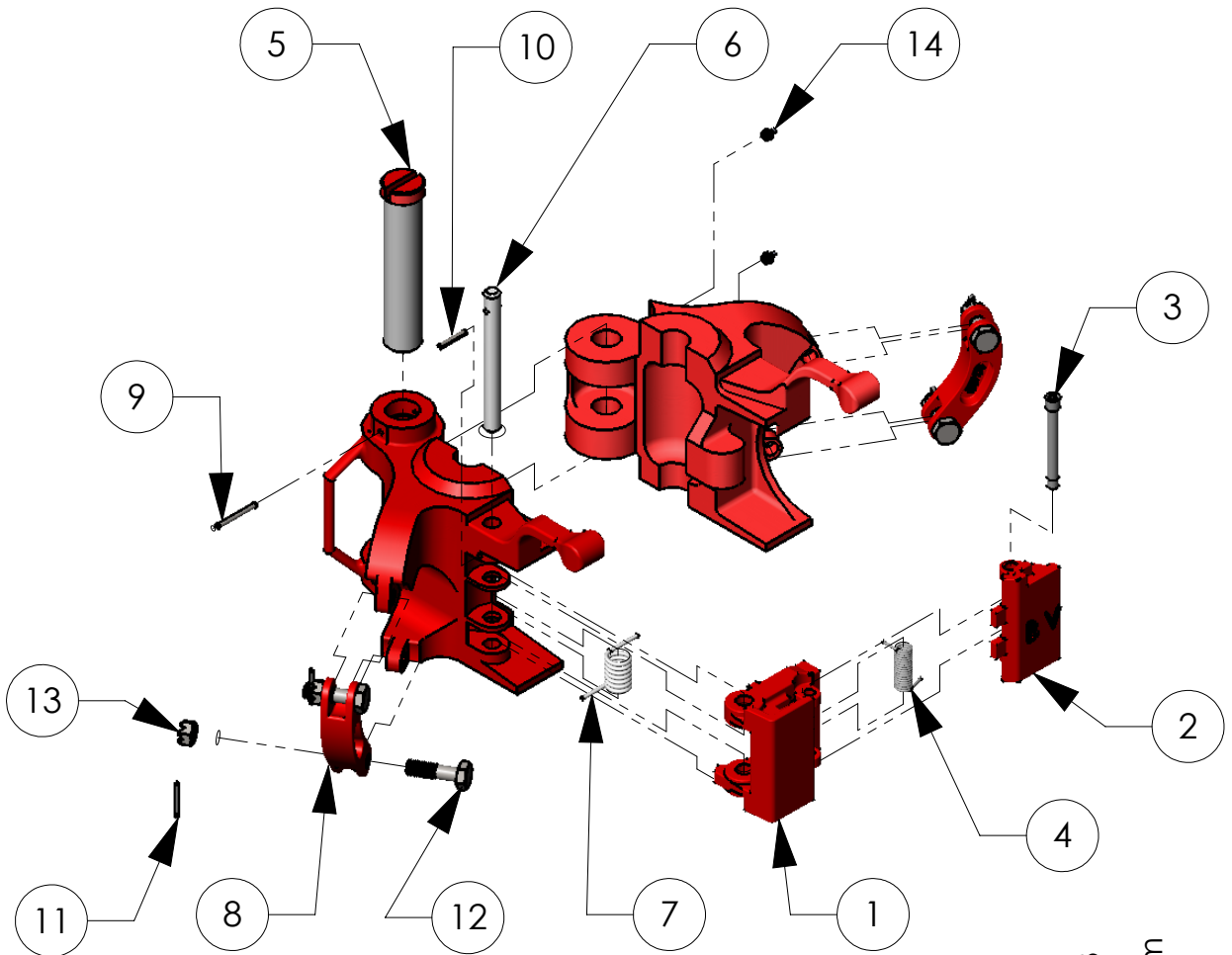

TA-65 SHOWN

BVM CORPORATION
430 S. NAVAJO STREET, DENVER CO 80223
PHONE: 303-975-1402; FAX: 303-975-0981
www.bvmcorp.com; sales@bvmcorp.com

BVM CENTER LATCH ELEVATOR TYPE "TA"

SPECIFICATION CENTER LATCH ELEVATOR

API SIZE	TYPE OF STYLE	TYPE TA-35 35-TOP CAP.		TYPE TA-65 65-TOP CAP.		TYPE TA-100 100-TOP CAP.		TYPE TA-150 150-TOP CAP.	
		PART NO	WEIGHT (lbs)	PART NO	WEIGHT (lbs)	PART NO	WEIGHT (lbs)	PART NO	WEIGHT (lbs)
1.05"	For 1.050" NON UPSET TUBING	32387-150	35.5	--	--	--	--	--	--
	For 1.050" UPSET TUBING	32387-151	35.5	--	--	--	--	--	--
1.315"	For 1.315" NON UPSET TUBING	32387-152	39.0	--	--	--	--	--	--
	For 1.315" UPSET TUBING	32387-153	39.0	--	--	--	--	--	--
1.66"	For 1.66" NON UPSET TUBING	32387-154	38.0	32385-154	64.5	--	--	--	--
	For 1.66" UPSET TUBING	32387-155	38.0	32385-155	64.5	--	--	--	--
1.9"	For 1.9" NON UPSET TUBING	32387-156	38.0	32385-156	64.0	--	--	--	--
	For 1.9" UPSET TUBING	32387-157	38.0	32385-157	64.0	--	--	--	--
2 3/8"	For 2 3/8" NON UPSET TUBING	32387-158	37.0	32385-158	64.0	32383-158	117.0	--	--
	For 2 3/8" UPSET TUBING	32387-159	37.0	32385-159	63.0	32383-159	117.0	--	--
	For 2 3/8" I.U.D.P. having A.P.I. Reg or F.H. Tool Joint	32387-109	37.0	32385-109	63.0	32383-109	117.0	--	--
	For 2 3/8" E.U.D.P. having A.P.I.I.F. Tool Joint	32387-115	37.0	32385-115	63.0	32383-115	117.0	--	--
2 7/8"	For 2 7/8" NON UPSET TUBING	32387-160	36.5	32385-160	62.0	32383-160	117.0	--	--
	For 2 7/8" UPSET TUBING	32387-161	36.5	32385-161	62.0	32383-161	117.0	--	--
	For 2 7/8" I.U.D.P. having A.P.I. Reg or F.H. Tool Joint	32387-108	36.5	32385-108	62.0	32383-108	117.0	--	--
3 1/2"	For 2 7/8" E.U.D.P. having A.P.I.I.F. Tool Joint	32387-101	36.5	32385-101	62.0	32383-101	117.0	--	--
	For 3 1/2" I.U.D.P. having A.P.I. Reg, F.H. or X Hole Tool Joint	--	--	32386-102	83.0	32384-102	158.0	--	--
	For 3 1/2" E.U.D.P. having A.P.I.I.F. Tool Joint	--	--	32386-103	83.0	32384-103	157.0	--	--
4"	For 3 1/2" NON UPSET TUBING	--	--	32386-162	83.0	32384-162	158.0	--	--
	For 3 1/2" UPSET TUBING	--	--	32386-163	83.0	32384-163	158.0	--	--
	For 4" NON UPSET TUBING	--	--	32386-164	82.0	32384-164	157.0	--	--
4 1/2"	For 4" UPSET TUBING	--	--	32386-165	82.0	32384-165	157.0	--	--
	For 4" I.U.D.P. having A.P.I. Reg, F.H. or X Hole Tool Joint	--	--	32386-104	82.0	32384-104	157.0	--	--
	For 4" E.U.D.P. having A.P.I.I.F. Tool Joint	--	--	32386-105	82.0	32384-105	156.0	--	--
5 1/2"	For 4 1/2" NON UPSET TUBING and 4 1/2" CASING	--	--	32386-129	81.0	32384-129	156.0	--	--
	For 4 1/2" UPSET TUBING	--	--	32386-167	81.0	32384-167	156.0	--	--
	For 4 1/2" I.U.D.P. having A.P.I. Reg, F.H. or X Hole Tool Joint	--	--	--	--	--	--	--	--
6 5/8"	For 5 1/2" I.U.D.P. having A.P.I. Reg or F.H. Tool Joint	--	--	--	--	29960-107	350.0	32754-107	430.0
	For 5 1/2" CASING	--	--	--	--	29960-132	350.0	32754-132	430.0
7"	For 6 5/8" CASING	--	--	--	--	29960-135	350.0	32754-135	430.0
7 5/8"	For 7" CASING	--	--	--	--	29960-136	350.0	32754-136	430.0
8 5/8"	For 7 5/8" CASING	--	--	--	--	29960-137	350.0	32754-137	430.0
8 5/8"	For 8 5/8" CASING	--	--	--	--	29960-139	350.0	32754-139	430.0

ITEM NO.	PART NAME	QTY	TA 35		TA 65		TA 65			
			1.050" - 2.875"		1.660" - 2.875"		3 1/2" - 4 1/2"			
			26.67mm - 73.03mm		42.16mm - 73.03mm		88.9mm - 114.3mm			
			WEIGHT (lbs)	WEIGHT (lbs)	WEIGHT (lbs)	WEIGHT (lbs)	WEIGHT (lbs)			
	LATCH LOCK ASSEMBLY		32484	4.9	32382	9.2	32382	9.2		
1	LATCH	1	32446	3.0	32380	6.3	32380	6.3		
2	LATCH LOCK	1	32447-1	1.6	32381	2.5	32381	2.5		
3	LATCH LOCK PIN	1	36685	0.1	36208	0.3	36208	0.3		
4	LATCH LOCK SPRING	1	32483	0.1	32469	0.1	32469	0.1		
5	HINGE PIN	1	32917	3.9	32914	4.9	32916	4.9		
6	LATCH PIN	1	32424-4	0.5	32424-3	0.9	32424-2	0.9		
7	LATCH SPRING	1	32482	0.2	32470	0.2	32470	0.2		
8	LINK BLOCK	2	23404	1.4	32430	2.0	32430	2.0		
9	HINGE PIN RETAINER	1	40050-22-0	0.1	40040-18-0	0.1	40040-22-0	0.1		
10	LATCH PIN RETAINER	1	40030-12-0	0.1	40030-12-0	-	-	-		
11	COTTER PIN	2	30AB0-12-0	0.3	30AB0-12-0	0.1	30AB0-12-0	0.1		
12	LINK BLOCK BOLT	2	23406	0.1	939051-65	0.3	939051-65	0.3		
13	LINK BLOCK NUT	2	6808C-00-5	0.1	6810C-00-5	0.1	6810C-00-5	0.1		
14	GREASE FITTING	2	940308-1	0.0	940308-1	0.1	940308-1	0.1		
ITEM NO.	PART NAME	QTY	TA 100		TA 100		TA 100		TA 150	
			2 3/8" - 2 7/8"		3 1/2" - 4 1/2"		5 1/2" - 8 5/8"		5 1/2" - 8 5/8"	
			60.33mm - 73.03mm		88.9mm - 114.3mm		138.7mm - 219.08mm		139.7mm - 219.01mm	
			WEIGHT (lbs)	WEIGHT (lbs)	WEIGHT (lbs)	WEIGHT (lbs)	WEIGHT (lbs)	WEIGHT (lbs)	WEIGHT (lbs)	
	LATCH LOCK ASSEMBLY		32382	9.2	32382	9.2	32753	22.0	32753	22.0
1	LATCH	1	32380	6.3	32380	6.3	32752	14.6	32752	14.6
2	LATCH LOCK	1	32381	2.5	32381	2.5	32757	6.6	32757	6.6
3	LATCH LOCK PIN	1	36208	0.3	36208	0.3	36207	0.6	36207	0.6
4	LATCH LOCK SPRING	1	32469	0.1	32469	0.1	32758	0.1	32758	0.1
5	HINGE PIN	1	32915-1	4.9	32919-1	4.9	29963	6.2	32924	6.2
6	LATCH PIN	1	32424-5	0.9	32424-1	0.9	29334	2.9	34242-1	2.9
7	LATCH SPRING	1	32470	0.2	32470	0.2	32760	0.2	32760	0.2
8	LINK BLOCK	2	32430	2.0	32430	2.0	9519	5.4	9519	5.4
9	HINGE PIN RETAINER	1	40040-24-0	0.1	40040-24-0	0.1	40040-32-0	0.1	40040-28-0	0.1
10	LATCH PIN RETAINER	1	40040-12-0	0.1	40040-12-0	-	-	-	-	-
11	COTTER PIN	2	30AB0-12-0	0.1	30AB0-12-0	0.1	30AB0-14-0	0.1	30AB0-14-0	0.1
12	LINK BLOCK BOLT	2	939051-65	0.3	939051-65	0.3	8145	0.4	8145	0.4
13	LINK BLOCK NUT	2	6810C-00-5	0.1	6810C-00-5	0.1	6812C-00-5	0.1	6812C-00-5	0.1
14	GREASE FITTING	2	940308-1	0.1	940308-1	0.1	940308-1	0.1	940308-1	0.1