

## SJH

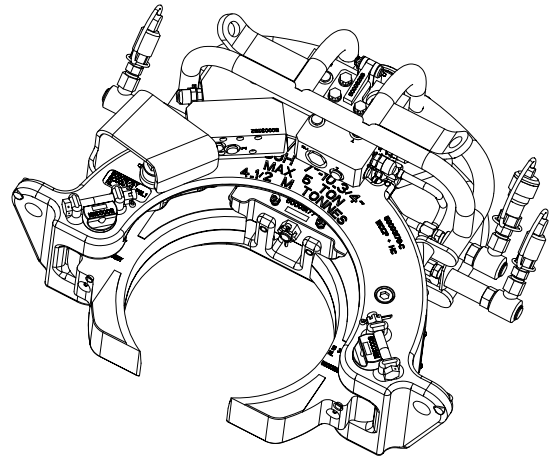

The SJH horizontal pick up elevator is designed to pick up tubulars lying flat on a surface without having to lift the tubulars prior to closing the elevator. The elevator is capable of lifting drill pipe, recessed/zip lift drill collars and casing. It will handle single joints of pipe straight from cantilever to off-line stand building systems.

Load Rating (sTon/Tonne)	Size inches (mm)	Pipe type	Appr. weight (lbs/kg) (incl jaws)
5 / 4.5	2.3/8 - 4.1/2 (60.3-114.3)	Tbg & Dp	100 / 45
5 / 4.5	4.1/2 - 7.5/8 (114.3-193.7)	Tbg & Dp	111 / 51
5 / 4.5	7 - 10.3/4 (177.8-273.1)	Csg	132 / 60

## SJL

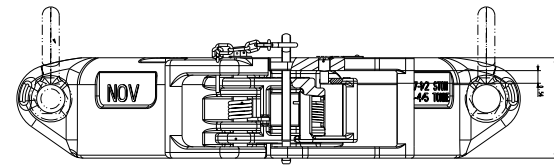
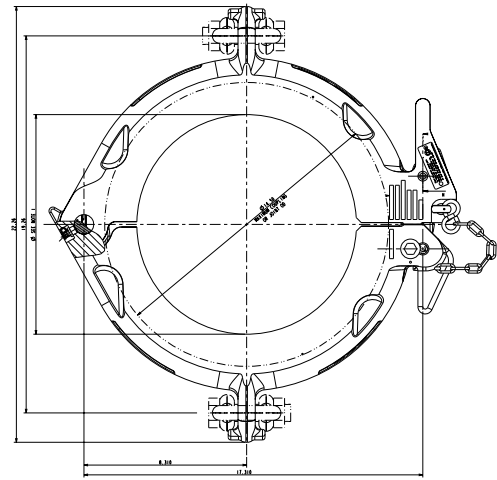

SJL and SPL single-joint, center-latch elevators are designed to replace unsafe rope slings for hoisting collar-type pipe into position. The SJL 90° elevator enables the crew to handle pipe properly, help avoid damage to pipe threads and reduce the chances of accident or injury. The SPL elevator is the same as the SJL elevator except that the SPL elevator is designed for use on tapered pipe, conforming to API specifications for extreme line casing.

Load Rating (sTon/Tonne)	Size Range inches (mm)	Max. Weight Range lbs. (kg.)
5 / 4.5	2.7/8 - 13.1/2 (60.3 - 114.3)	45-342.9 (20-55)
7.5 / 6.8	12.7/8 - 30 (355.6 - 762)	121-404 (55-183.3)

## SPL

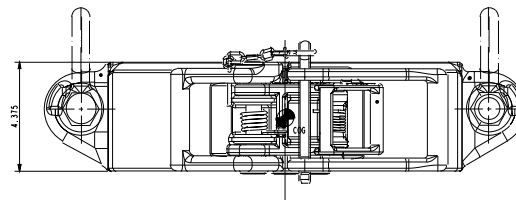
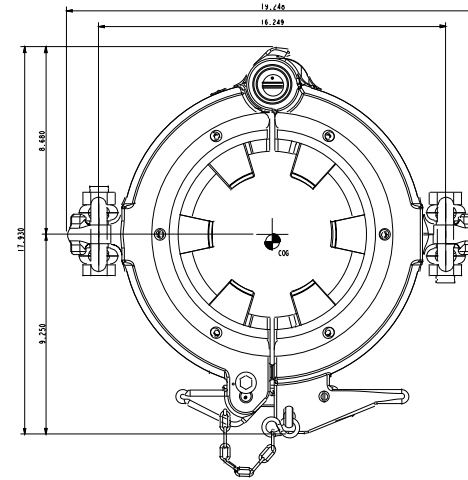

SJL and SPL single-joint, center-latch elevators are designed to replace unsafe rope slings for hoisting collar-type pipe into position. The SJL 90° elevator enables the crew to handle pipe properly, help avoid damage to pipe threads and reduce the chances of accident or injury. The SPL elevator is the same as the SJL elevator except that the SPL elevator is designed for use on tapered pipe, conforming to API specifications for extreme line casing.

Type	Load Rating (sTon/Tonne)	Size Range inches (mm)	Max. Weight Range lbs. (kg.)
SPL 5	5 / 4.5	2.7/8 - 7.5/8 (60.3 - 114.3)	77-108 (35-49)
SPL 12	5 / 4.5	2.3/8-5 (60.3-127)	86 (39)
SPL 18	5 / 4.5	2.3/8-6.5/8 (60.3-168.3)	79-94 (36-49)

## DSJX Heavy Duty

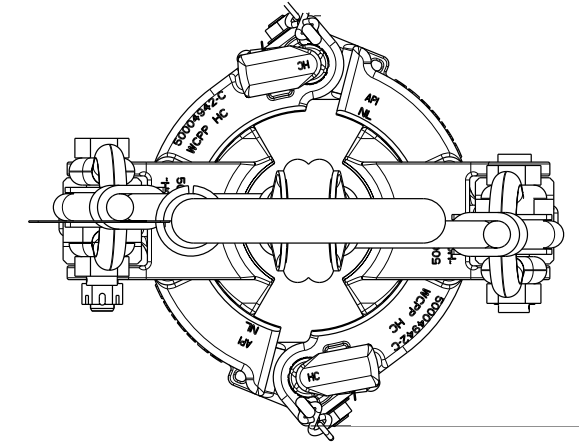
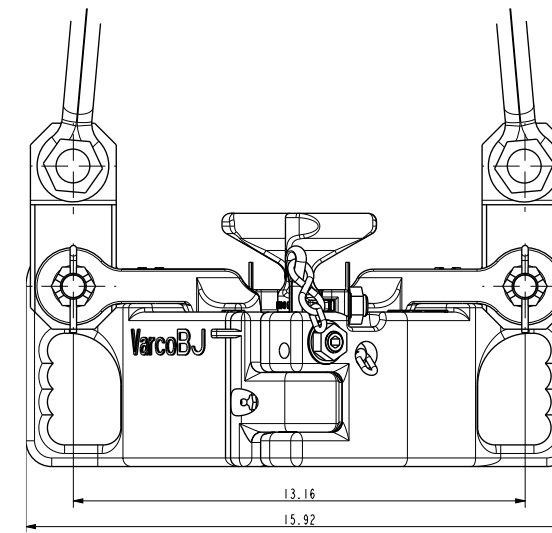

The D-SJX is the heavy duty version of the SJX, capable of handling doubles and triples up to 12 STon / 10.9 Tonne.

- High capacity single joint - 12 sTons (106 kN) API rating
- DSJX is designed for running doubles or triples during off-line standbuilding
- DSJX used special inserts to handle a range of pipe types
- Elevator can handle drill pipe and square shoulder pipe

Load Rating (sTon/Tonne)	Size Range Inches (mm)	Max. Weight Range lbs. (kg.)
12/11	3.1/2-7.1/2 (88.9-190.5)	79-89 (36-40)

## SJX

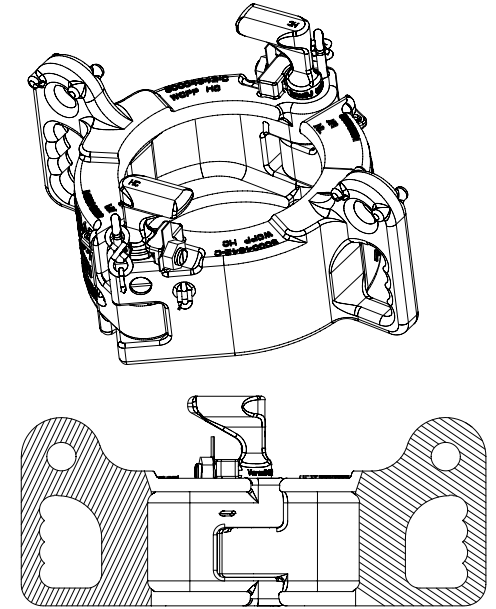

The SJX single joint elevator is designed for running single joints of tubing and casing from V-door to well center. It is double hinged for use with the CRT Casing Running Tool, or any other stabberless operation. Ergonomically designed handles with cast on stop pins prevent the lifting sling shackles from pinching hands. Suitable for loads up to 5 sTon / 4.5 Tonne.

- Designed for pick-up and running single joints of tubing and casing from v-door to well center
- 2-way access due to double hinge pin arrangement
- Double hinged for use with CRT Casing Running Tool
- No loose parts, as hinge pins are contained within the body halves
- Clear visual gripping points for safe operation
- Ergonomically designed handles, with cast on stop pins, prevent the lifting sling shackles from pinching hands and prevent shackles from getting stuck underneath the casing coupling while hoisting.
- The position of lifting ears prevents lifting tubing and casing with the SJX upside down.
- Verification "latched-and-locked" safety pin
- Lightweight for easy manual handling; on the average, 45% lighter than other single joints
- Designed and qualified according to API 8C rules
- Rubular sizes from 2 3/8" to 14"; information on larger sizes is available upon request
- Rating of 5 tons

Load Rating (sTon/Tonne)	Size Range Inches (mm)	Max. Weight Range lbs. (kg.)	Max. Weight Range (kg.)
5/4.5	4.1/2-10.3/4 (100.8-323.9)	37-67 (17-30)	17-30